

ASSIST II

ATMOSPHERIC SOUNDER SPECTROMETER
BY INFRARED SPECTRAL TECHNOLOGY

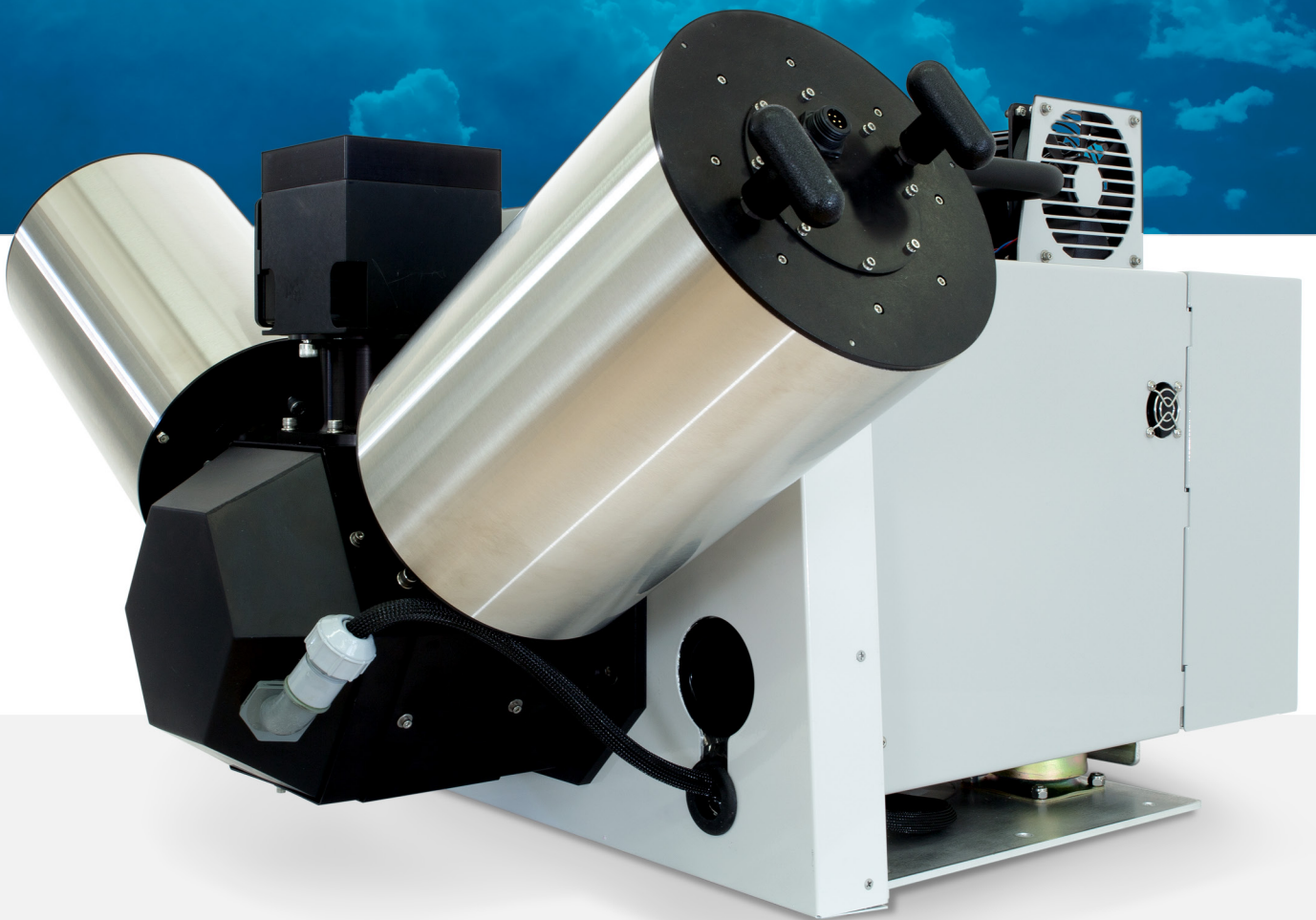

PERFORMANCE
WITHOUT
COMPROMISE



01 OVERVIEW

02 THE ADVANTAGES

03 TECHNICAL SPECIFICATIONS

04 APPLICATION EXAMPLES

05 DATA PRODUCTS

06 THE EDGAR™ SOFTWARE

07 CONFIGURING THE ASSIST II

08 ASSIST II GALLERY

09 LR TECH EXPERTISE

10 LR TECH PRODUCTS SHOWCASE



The extraordinary performance of the ground-based ASSIST-II remote sensing system coupled with the dedicated support of LR Tech in its field applications has enabled us to obtain highly useful vertical atmospheric profiles for research and environmental applications.

- Prof, William L. Smith Sr.

THE ASSIST II

The field deployable sounder that the atmospheric community has been waiting for

The ASSIST-II is a field deployable sounder which uses Fourier Transform technology. It is the latest development in ground based atmospheric sounding spectrometer. Its configuration is rugged, compact and can be adapted to various environment, such as ground and sea platforms. Thanks to its advanced software suite, it can be operated 24/7 to provide atmospheric profiles of various components at high temporal and spectral resolution as well as a wide choice of other applications.

THE ADVANTAGES

High spectral and temporal resolution

The ASSIST-II achieves a spectral resolution of 1 cm^{-1} over its entire spectral range ($3.3 - 18.2\ \mu\text{m}$, $550 - 3000\ \text{cm}^{-1}$) while offering a high temporal resolution by generating profiles in a near real-time fashion.

Compact field-deployable configuration

The ASSIST-II instrument and environmental enclosure configuration is compact and well adapted for remote locations. This allows its deployment to be as simple as possible, even in harsh environments.

Robust and rock solid radiometric calibration unit

The ASSIST-II is equipped with 2 high emissivity blackbodies individually and precisely calibrated to insure a perfectly calibrated instrument. This guarantees the highest accuracy for every final data products generated by the instrument.

User-friendly software

The EDGAR™ software acquire, calibrate and generate radiances and atmospheric profiles from the instrument in near real-time while keeping an eye out for any issues with the instrument to allow easy and minimum monitoring. It is doing so autonomously 24/7.

Automatic atmospheric profiles generation

Produce high accuracy atmospheric profiles of various components, such as temperature, moisture, Ozone (O_3), Carbon Dioxide (CO_2), Nitrous Oxide (NO_x) and more.

Unmatched usability and field support

The ASSIST-II provides extensive housekeeping data recording of temperatures, voltages, and humidity, as well as a remote control software suite. Just connect the ASSIST-II to the internet and an LR Tech expert can perform health monitoring and obtain an accurate diagnostic in minutes.



	Specification	Value	Units	Comment
Optical	Spectral range	500 to 5000 cm ⁻¹	cm ⁻¹	Optional extended range from 400 to 5000 cm ⁻¹
	Spectral resolution	1, 2, 4, 8, 16, 32, 64, 128	cm ⁻¹	Computer selectable, Maximum apodized resolution of 0.7 cm ⁻¹
		0.1 to 1000	nm	According to wavelength
	Nominal beam diameter at beam stop	2,54	cm	
	Metrology	15799,8	cm ⁻¹	HeNe gas tube laser
	Throughput	0.00805	sr · cm ²	
	Field of view (FOV)	45	mrad	
Field of view uniformity	± 5	%	Over 80% of the FOV	
Radiometric	NESR	2.5 x 10 ⁻⁹	W/sr/cm ² /cm ⁻¹	At 1300 cm ⁻¹
		2.5 x 10 ⁻¹⁰	W/sr/cm ² /cm ⁻¹	At 2000 cm ⁻¹ At 16 cm ⁻¹ spectral resolution and 1s observation time
	Raw Measurement rate	1	spectra/s	At maximum resolution
Atmospheric profile rate	0,5	profile/minute	At maximum resolution	
Operational	Dimensions	90.7 x 78.7 x 50	cm	ASSIST-II Instrument (L x W x H - (p. 7))
		96.2 x 182.2 x 102.5	cm	ASSIST-II Environmental Enclosure (L x W x H - (p. 7))
	Weight	122	kg	Including the environmental enclosure
	Power consumption	2	A	ASSIST-II Instrument on 115VAC
		1	A	ASSIST-II Instrument on 230VAC
		3	A	Environmental Enclosure on 115VAC
		1,5	A	Environmental Enclosure on 230VAC
	Temperature	-20 to 50	°C	With environmental enclosure
	Pressure	12 to 125	kPa	
	Humidity	0 to 90	%	Non condensing
	Calibration units (Blackbody cavities)	Effective emissivity	0,9985	-
Aperture diameter		6,98	cm	At cavity entrance
Temperature range		ambient to +70	°C	Down to -25 °C ambient temperature
Radiance uncertainty		<± 0.005	K	
Temperature stability		0,005	K	Over 120 seconds
Temperature resolution		0,001	K	
Temperature knowledge		± 0.1	K	Absolute

Figure 1 - ASSIST specifications table

TECHNICAL SPECIFICATIONS

FEATURES

STANDARD	Sealed interferometer
STANDARD	77°K stirling cooler (LN2 free)
STANDARD	Mid-Wave IR (InSb) and long-wave IR (HgCdTe (MCT)) detectors
STANDARD	Built-in calibration units composed of 2 high emissivity blackbodies
STANDARD	Portable field computer
1 LICENCE INCL.	Edgar instrumental control and data acquisition software
STANDARD	Web based remotely controllable power switch
STANDARD	Atmospheric temperature / moisture profile package
OPTIONAL	Trace gases (GHG's) concentration profile package
OPTIONAL	Emissivity/skin temperature retrieval package
OPTIONAL	Field deployable environmental enclosure (with temperature control)

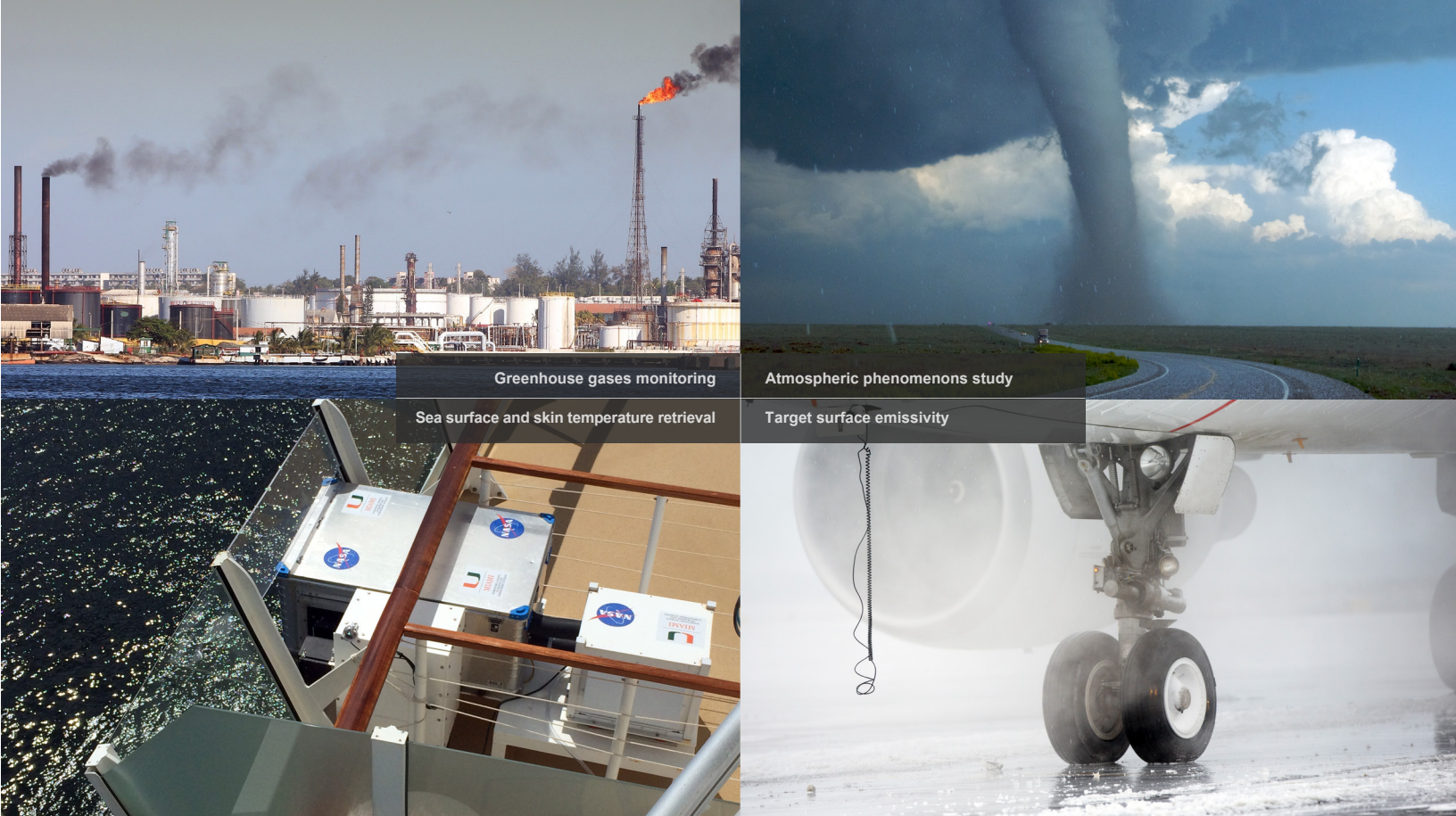

Greenhouse gases monitoring
 Atmospheric phenomena study
 Sea surface and skin temperature retrieval
 Target surface emissivity

WHAT CAN YOU MEASURE WITH THE LR TECH ASSIST II™ TECHNOLOGY?

The radiance spectra measured with the ASSIST-II instrument are sensitive to atmospheric profile features caused by the absorption and re-emission of the radiation emitted by atmospheric gases. Figure 2 shows the regions of the spectrum measured by ASSIST-II that are optically active to the different gases.

Most of the infrared spectrum observed with the ASSIST-II instrument provides useful information on the trace gases structure of the atmosphere. Its high sensitivity is essential for the study of the chemical and physical properties of the atmosphere column or any other target.

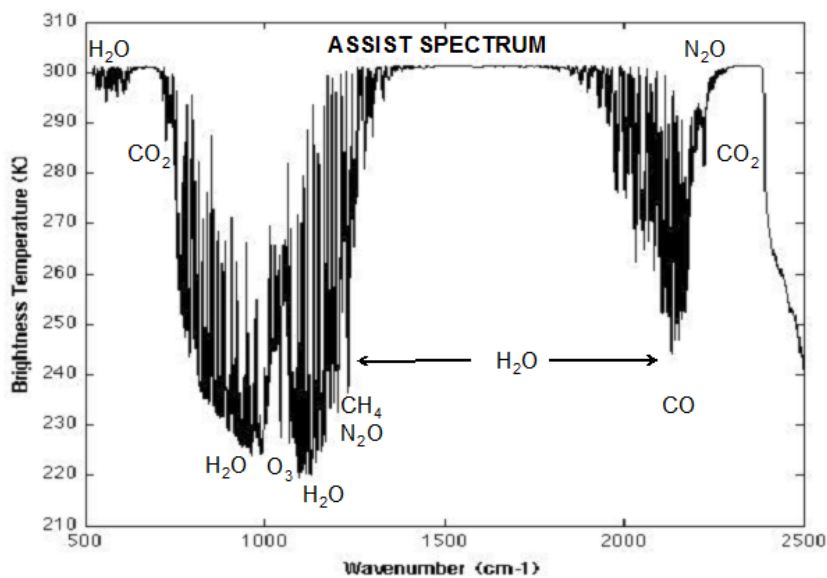

Figure 2. ASSIST-II Brightness temperature spectra showing the spectral regions where specific gases are optically active

DATA PRODUCTS

The ASSIST-II incorporates all the accessories required to allow autonomous operation into a simple and compact enclosure. The ASSIST-II comes equipped with its own calibration unit, composed of 2 high emissivity blackbodies, allowing an absolute radiometric accuracy of 1% at ambient temperature.

Various applications can be supported and enhanced by the usage of the ASSIST-II atmospheric sounder. Different optional packages are available to get a tailor-fit instrument for your specific application.

ATMOSPHERIC TEMPERATURE / MOISTURE PROFILE PACKAGE

The ASSIST-II can produce atmospheric profiles of temperature and moisture at up to 4km altitude in an autonomous way. The precisely calibrated radiance of the ASSIST-II allows accurate result and high temporal resolution compared to radiosonde data. A new profile is obtained more than once every 2 minutes (p. 6, #3).

TRACE GASES (GHG'S) CONCENTRATION PROFILE PACKAGE

Just like with the atmospheric profiles of temperature and moisture, the ASSIST-II can automatically generate trace gases concentration profiles at high temporal resolution. The available gases are :

- Ozone (O₃)
- Carbon Monoxide (CO)
- Methane (CH₄)
- Nitrous Oxide (NO_x)
- Carbon Dioxide (CO₂)
- Aerosols

EMISSION AND SKIN TEMPERATURE RETRIEVAL

The ASSIST-II can be used to measure the sea surface skin temperature, which is the temperature in the exchange layer between the water and the atmosphere, about 1mm thick. Air masses in the Earth's atmosphere are highly modified by sea surface temperatures within a short distance of the shore.

The same robust algorithm is used by the ASSIST-II instrument for the determination of surface emissivity and skin temperature from ASSIST-II sky and near nadir radiance observations.

O₃ Profile Cross-section

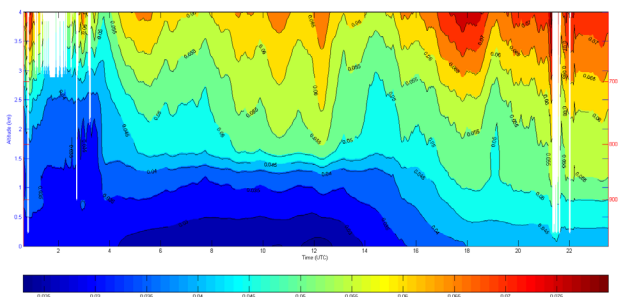

Weekly Average SST

2011/01/30 - 2011/02/05

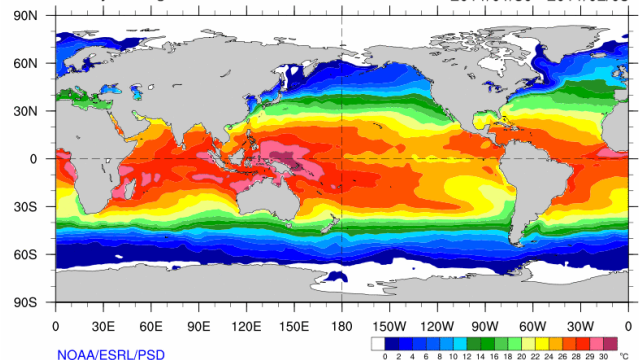

THE EDGAR™ SOFTWARE

The Edgar™ software is the tool of choice to be in total control of the ASSIST-II instrument. It is used to control the hardware, generate and manipulate raw data (interferograms), and produce numerous derived data products automatically.

Edgar™ supports a variety of industry-standard formats, including Matlab™, NetCDF and binary formats.

The Edgar™ software package also provides you with a set of tools allowing easy remote monitoring of the instrument. Alarms can be setup to automatically email the instrument operator when certain conditions are met, making it easier to prevent problems from happening and keeping the instrument running 24/7. Tools are also provided to make the instrument remotely controllable when connected to the internet.

When operating the ASSIST-II instrument with the Edgar™ software, a suite of customizable scripts are provided to perform the acquisition and processing of the instrumental data as well as perform instrument monitoring tasks. Multiple parameters are available to customize the instrument output to match your exact needs.

The ASSIST-II scripts will acquire the raw data and perform data calibrations to obtain calibrated radiances, brightness temperature and multiple other products used to monitor the instrument performances over time.

1

Raw Data

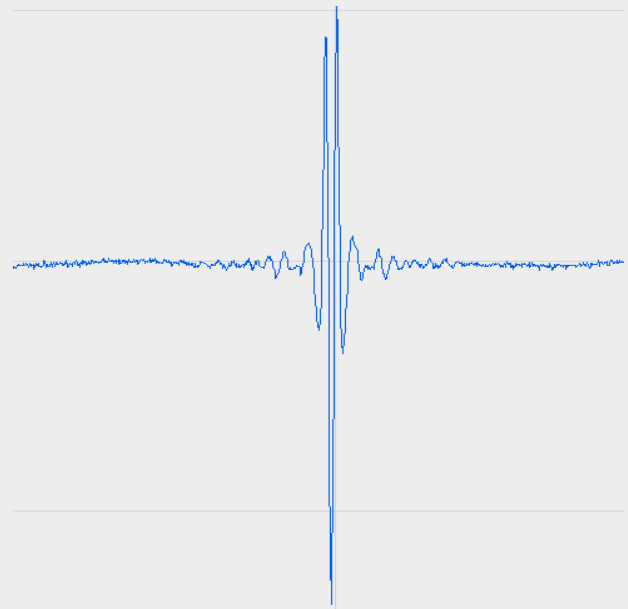

2

Calibrated Radiance

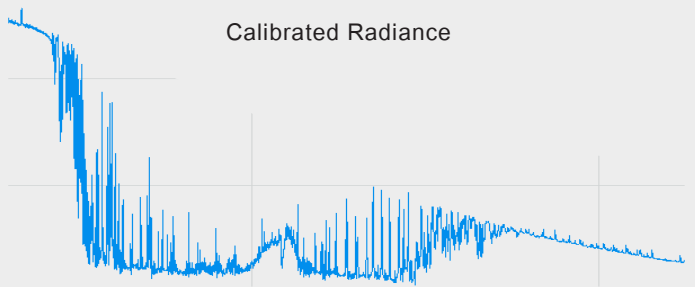

3

Atmospheric Profile Retrievals

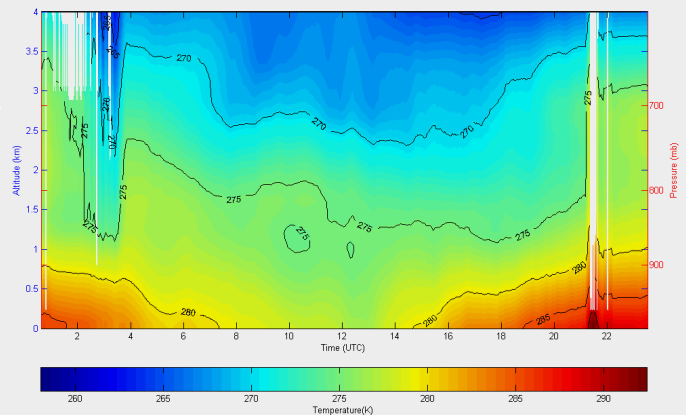

CONFIGURE YOUR ASSIST II™ INSTRUMENT ACCORDING TO YOUR NEEDS

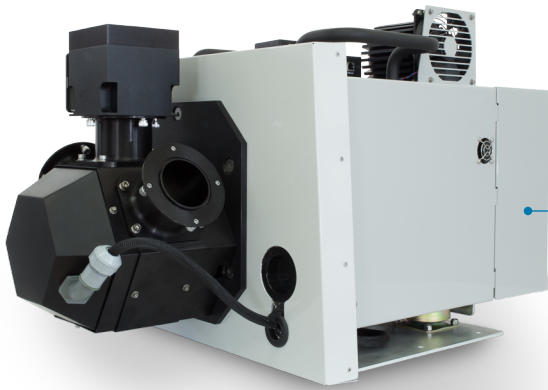

ASSIST II
ASSIST-II



Acquisition laptop computer

CFP-ASSVSR

Environmental enclosure with temperature control

LEFT : ASSIST II Container
RIGHT : Air conditioning unit

ENC-2

High emissivity blackbodies

BB-ASSIST II

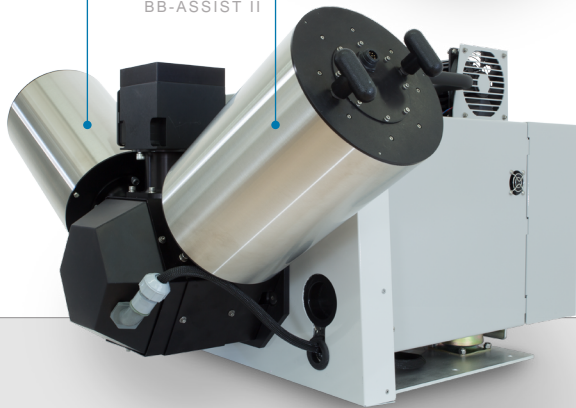

TOP VIEW

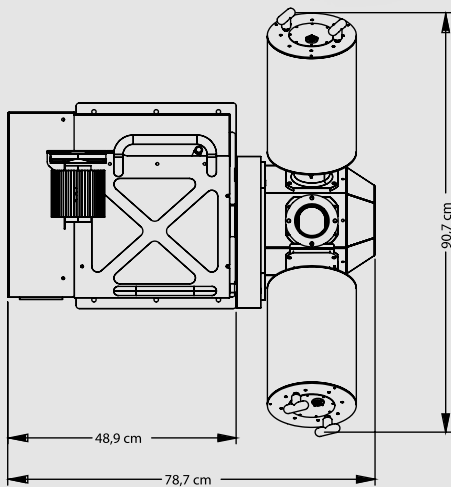

SIDE VIEW

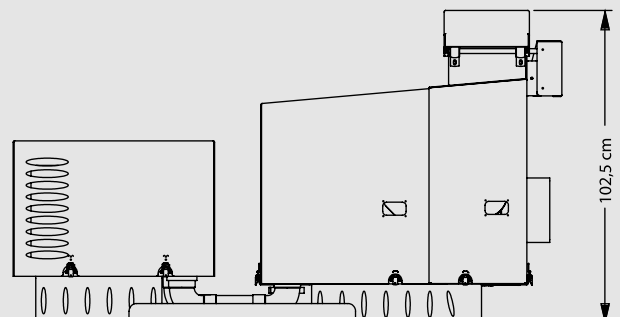
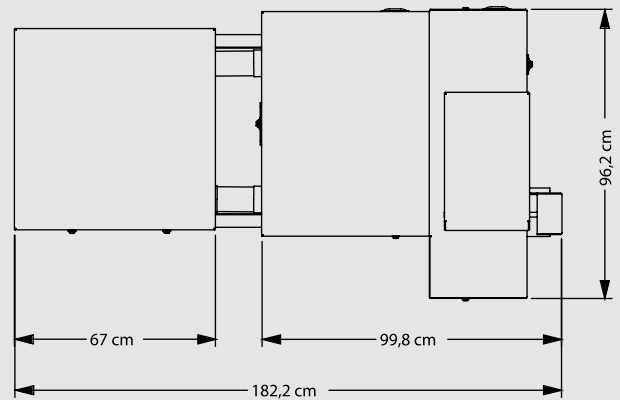
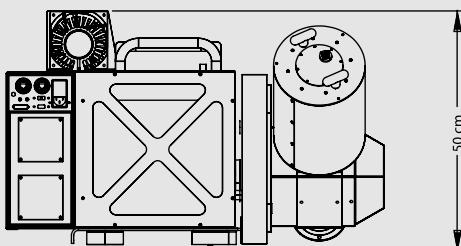

SOFTWARE PACKAGES

Atmospheric temperature / moisture profile package

ASSIST-CAL

Temperature Profile Cross-section

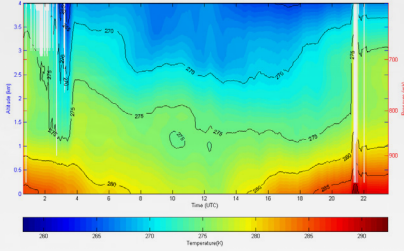

Trace gases (GHG's) concentration profile package

SOFT-2

O₃ Profile Cross-section

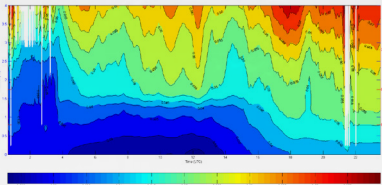

Emissivity/skin temperature retrieval package

SOFT-3

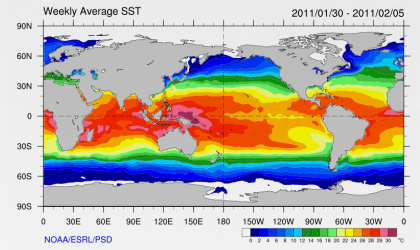

ASSIST-II instrument in its environmental enclosure on a field deployment in Beijing, China.

ASSIST-II Calibration Unit, composed of 2 high emissivity blackbodies and a motorized pointing mirror.





NAST-I

In 2009, LR Tech upgraded the NAST-I instrument, from NASA. NAST-I provides experimental observations validate radiance measurements and geophysical products obtained from various instruments installed on satellite platforms. It is also used to finalize the specifications and to test proposed designs and data processing algorithms for the Cross-Track Infrared Souder (CrIS).



ARM MOBILE FACILITY 2

In 2010, LR Tech has been awarded a contract to provide an ASSIST-II atmospheric sounder to be installed in the ARM Mobile Facility 2. The AMF is equipped with multiple instruments, ranging from standard meteorological instrumentation, broadband and spectral radiometer suite, and remote sensing instruments. It is designed to operate in any environment, from the cold of the Arctic to the heat of the tropics.

LR TECH EXPERTISE JOIN THE WORLDWIDE USERS

EPA ASPECT

The office of emergency management of the US Environmental Protection Agency (EPA) awarded a contract to LR Tech in 2004 to overhaul the control of the ASPECT high speed infrared spectrometer. Since then, EPA has recently replaced their previous LR Tech upgraded FT-IR system by VSR™ instruments. The VSR™ instruments installed on ASPECT airborne platform consist of a VSR™ with optional LR Tech calibration source and pointing mirror system.

FOCAL PLANE ARRAY

Over the years, LR Tech has developed different types of custom detectors, including multi-pixels detectors. Contrary to conventional arrays, LR Tech multi-element detectors provide spatial information while at the same time preserving signal dynamic range. Combined with a variety of fast scanning spectro-radiometers, these arrays have demonstrated the utility of spatial resolution and its ability to enhance sensitivity. These arrays are composed of 64 elements (8X8 pixels) with a total surface area of 3X3 mm.

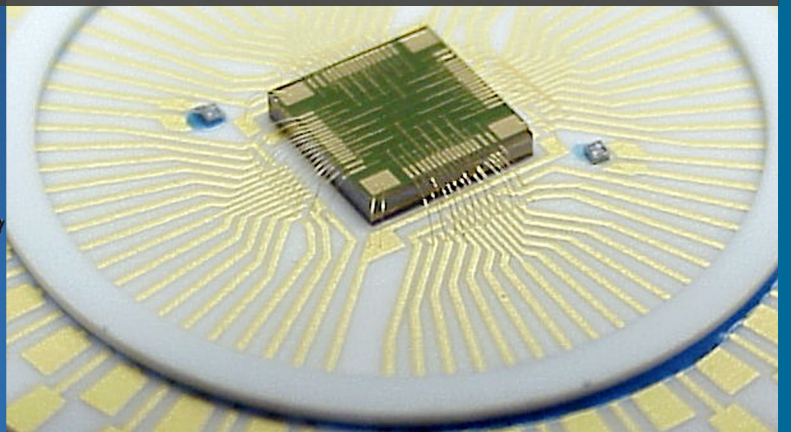



VSR

The Versatile Spectroradiometer (VSR) is a compact high sensitivity spectroradiometer which uses Fourier Transform Infrared (FT-IR) technology. Its high speed, yet robust operation allows its usage in different scenarios, from laboratory usage to airborne and heavy vibrations environments. The VSR can provide real-time high resolution spectral information on slow and fast occurring phenomenon, as well as perform material and target signature analysis.

LR TECH PRODUCTS SHOWCASE

WE HAVE THE RIGHT PRODUCT FOR YOUR APPLICATION

AIRBORNE SPECTRO-RADIOMETER

LR has developed a new Fourier transform spectrometer (FTS) for airborne applications. Our new compact airborne spectro-radiometer is a small and lightweight FTS based on a two-port optical design. It uses a Stirling-cooled detector encompassing MCT (650 – 1875 cm^{-1}) and InSb (1750 – 5745 cm^{-1}) sensors allowing a broad spectral coverage (15.4 – 1.75 μm).





LR Tech inc.
47 Saint-Joseph street
Lévis, Qc, G6V 1A8
Canada

lrtech.ca

北京吉亭时代仪器有限公司
北京市朝阳区华
威里2号 楼19H
100021

www.jetting.com.cn

DISCLAIMER This product description document is not a guide to product usage. Further information is available from LR Tech inc. Product specifications may change without notice. © LR Tech inc.

Product code 2-ALR-001-01-RA